

# 7 APPENDIX

## 7.1 MAINTENANCE

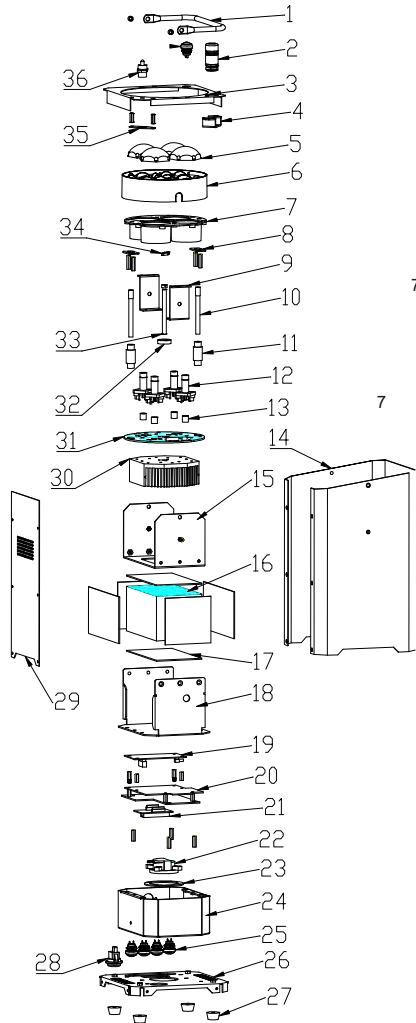

No.	Item Name
1	Hanger
2	Wireless Receiver
3	Top cover
4	Fix board of wireless Receiver.
5	Lens.
6	Plastic cover 1 for fixing lens.
7	Plastic cover 2 for fixing lens.
8	Fixed board for zoom
9	Connecting bracket for zoom.
10	Zooming supporter
11	Zooming pillar
12	Light Guid Bart
13	light barrier.
14	Body cover A
15	Arm
16	Lithium battery
17	Foam pad.
18	Lithium battery holder.
19	Wireless receiver board.
20	Driver board
21	Display board.
22	Recharge socket A.
23	Bearer for recharge socket A
24	PCB holder.
25	Button of display board
26	Full-featured control panel.
27	Foot.
28	Power switch.
29	Body cover B.
30	Cooling aluminum.
31	Led board.
32	Zooming nut.
33	Zooming screw.
34	Connector for lens
35	Fixed board for LED charge indicator.
36	LED charge indicato.

# USER MANUAL

4X10W RGBW 4 IN 1

Led Wireless Battery Zoom Light

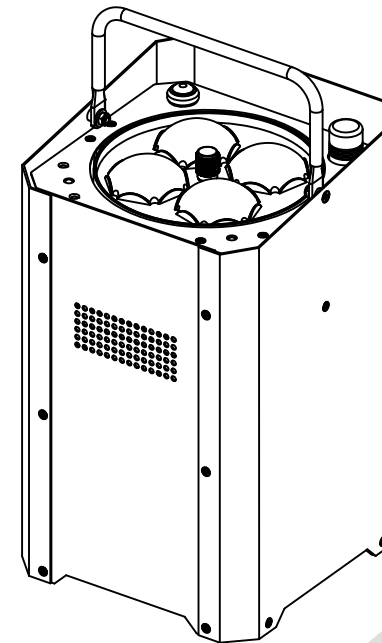

Please Read Over This Manual Before Operating The Light Fixture

# T ABLE OF CONTENTS

**PART 1 PRODUCT SPECIFICATIONS.....1.**

1.1--TECHNICAL SPECIFICATIONS.....1.

1.2--DIMENSIONS.....1.

1.3--SAFETY WARNING.....2.

**PART 2 INSTALLATION.....3.**

2.1--OPERATING POSITION.....3.

2.2--CHARGING INPUT.....3.

2.3--FUNCTION OPERATION.....4.

2.4--OTHER OPERATIONS.....4.

**PART 3 USING THE MENU.....5.**

3.1--BASIC.....5.

3.2--MENU.....5.

3.3--EDIT STATIC COLOUR.....6.

3.4--ACTIVATING AUTO PROGRAMS.....6.

3.5--DMX512 SETTINGS.....6.

3.6--RUN MODE.....6.

3.7--PERSONALITY.....7.

3.8--SPECIAL SETTINGS.....7.

3.9--EDITING CUSTOM PROGRAMS.....7.

3.10--WHITES CALIBRATION.....8.

3.11--RGB CALIBRATION.....8.

3.12--WDMX SETTINGS.....8.

**PART 4 USING DMX512 CONTROLLER.....9.**

4.1--BASIC ADDRESSING.....9.

4.2--CHANNEL ASSIGNMENT.....9.

**PART 5 EASYPLAY REMOMTE CONTROL.....15.**

5.1--KEY FUNCTIONS.....15.

5.2--STATIC CONTROLS.....15.

5.3--EFFECT CONTROLS.....15.

5.4--COLOR CONTROLS.....15.

**PART 6 BATTERY CHARGING.....16.**

**PART 7 APPENDIX.....17.**

7.1--MAINTENANCE.....17.

## 6.3 CHARGER SPECIFICATIONS

Voltage: AC100-240V, 50/60Hz  
Output: DC24V, 3A

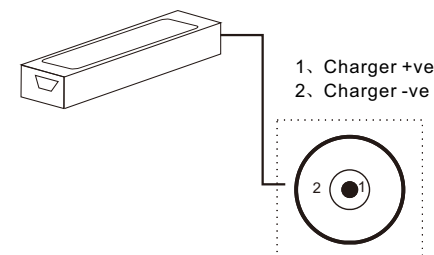

## 6.4 FLIGHTCASE SPECIFICATIONS

Voltage: AC100-240V, 50,60Hz  
Rated Power: 300W  
Weight: 21KG  
Dimensions: 730 x 400 x 520mm

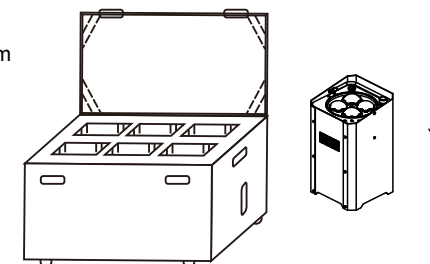

## 6.5 IMPORTANT FACTS:

### HOW TO CARE FOR YOUR BATTERY!

#### CHARGING

- DO NOT CHARGE FOR MORE THAN 24HRS
- RECHARGE WITHIN 3 DAYS OF USE
- CHARGE WITH FLIGHTCASE OPEN

#### STORING

- STORE WITH FULL LOAD
- TURN OFF AT BASE WHEN STORING FOR MORE THAN 7 DAYS
- STORE IN AN UPRIGHT POSITION

## 6 BATTERY CHARGING

### 6.1 BATTERY SPECIFICATIONS:

Type of battery: Lithium Battery  
 Voltage: 24V  
 Storage Capacity: 8800mAh  
 Charge Time: 8 hrs  
 Discharge Time: 8hrs (in fixture at full output)  
 Weight: 1.2Kg  
 Dimensions: 135X65X76mm

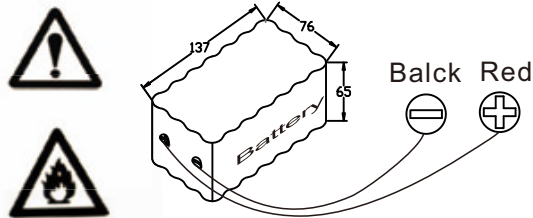

### 6.2 SPECIAL CONSIDERATIONS:

#### Charging

- Do not charge for more than 24 hours
- Always charge with flightcase open
- It is recommended to charge at a temperature between 0°C to 35°C
- Always recharge within 3 days of use
- Always charge with supplied charger

#### Operation

- Recommended ambient temperature is between 0°C to 35°C
- Always use fixture in a vertical or near-vertical position (<30deg. from vertical)
- Do not operate in a sealed enclosure with insufficient air flow

#### Storage

- Always store at a temperature below 35°C (below 25°C is best)
- Always store in a vertical position
- Always store fully charged
- It is important to carry out one full discharge and charge cycle every 3 months
- Always use the battery switch when storing for longer than 7 days
- Store in a dry environment away from direct sunlight

#### Maintenance

- Always switch off the battery switch when carrying out maintenance
- Do not allow battery contacts come into contact with fixture housing
- Do not link the positive and negative terminals in any way

## 1 PRODUCT SPECIFICATIONS

### 1.1 TECHNICAL SPECIFICATIONS

LED MODULE	
LED MODULE:	4pcsx10W (RGBW 4 in 1 LED)
Voltage	24VDC
Zoom Range	7~60°
Power	40W
Type of battery	Lithium Battery
IP Rating	IP 44
Operation Temperature	0°C~35°C (operating) 0°C~35°C (startup)
Dimensions	270x160x160mm
Weight	4.5Kg

### 1.2 DIMENSIONS

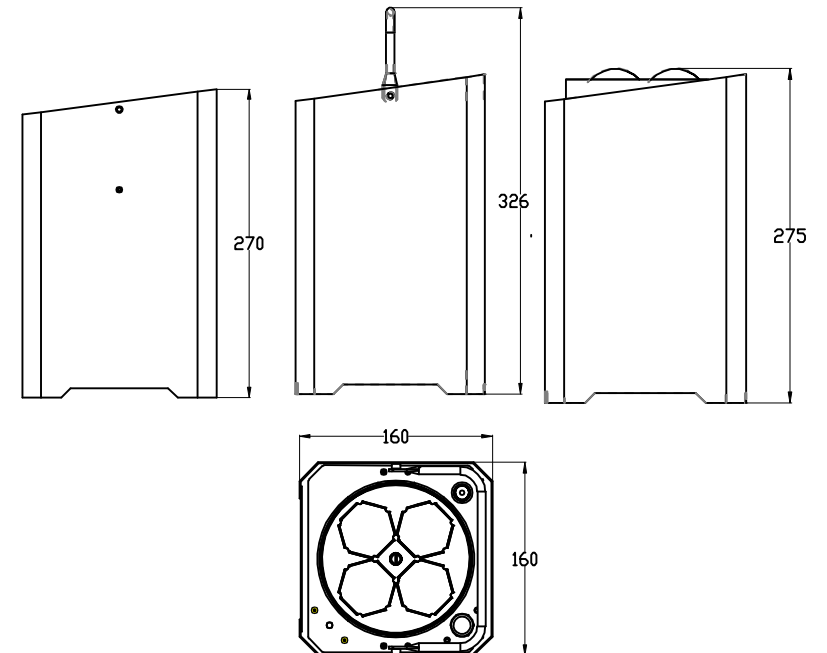

## 1.3 SAFETY WARNING

### IMPORTANT

**[ALWAYS READ THE USER MANUAL BEFORE OPERATION. ]**  
**[PLEASE CONFIRM THAT THE POWER SUPPLY STATED ON THE PRODUCT IS THE SAME AS THE MAINS POWER SUPPLY IN YOUR AREA.]**

- This product must be installed by a qualified professional.
- Always operate the equipment as described in the user manual.
- A minimum distance of 0.5m must be maintained between the equipment and combustible surface.
- The product must always be placed in a well ventilated area.
- Always make sure that the equipment is installed securely.
- Do not stand close to the equipment and stare directly into the LED light source.
- Always disconnect the power supply before attempting maintenance.
- Always make sure that the supporting structure is solid and can support the combined weight of the products.
- The earth wire must always be connected to the ground.
- Do not touch the power cables if your hands are wet.

### ATTENTION

- Do not operate in a sealed enclosure with insufficient air flow
- Do not operate in an environment with temperatures in excess of 45deg. C.
- Do not operate store in close proximity to source of fire.
- Always charge with supplied charger
- Do not charge for more than 24 hours
- Always turn off battery storage switch when storing for longer than 7 days
- Always store with full load
- Always charge with flightcase open
- Always carry out one full discharge and charge cycle every 3 months
- Always store in a dry environment away from direct sunlight

## 2 GETTING STARTED

### 2.1 OPERATING POSITION

- This lighting fixture is powered using a Lithium Battery which requires that the correct product orientation is always maintained for operation.

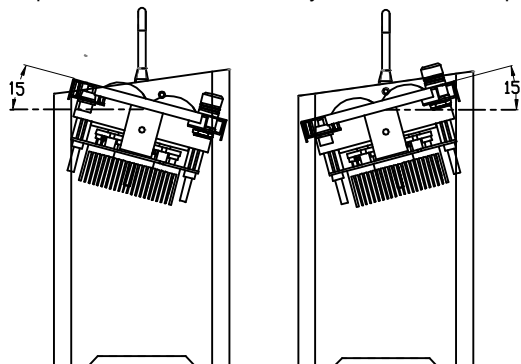

## 5 EASYPLAY REMOTE CONTROL

### 5.1 KEY FUNCTIONS

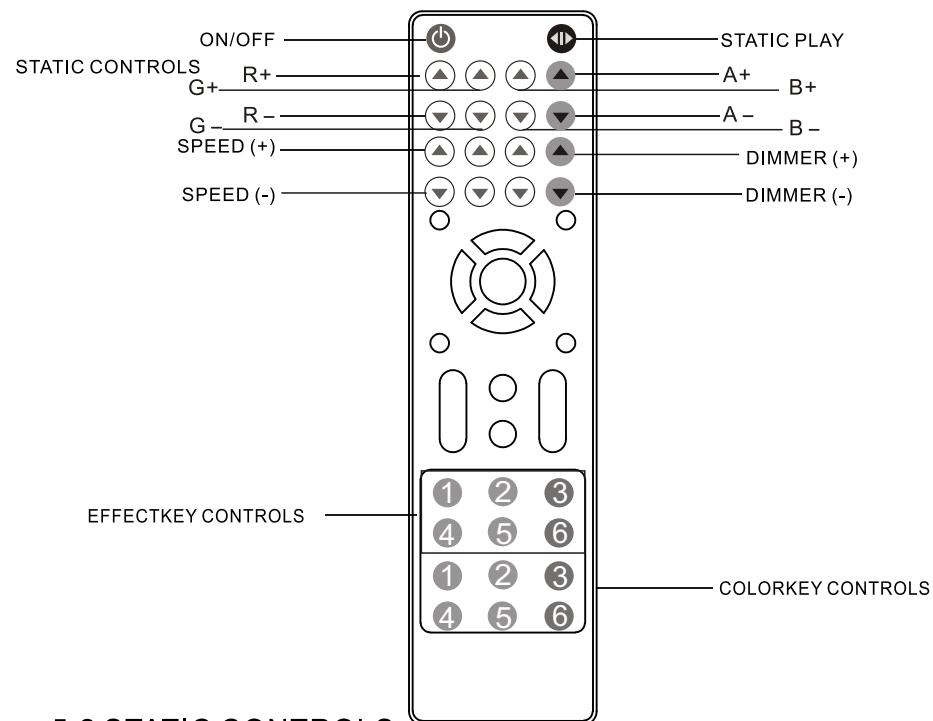

### 5.2 STATIC CONTROLS

- Select the [STATIC PLAY] key to enter the [STATIC] play mode.
- Adjust [STATIC] play using [RED], [GREEN], [BLUE] and [STROBE].
- Adjust light level using the [DIMMER] keys.

### 5.3 EFFECT CONTROLS

- Select from [EFFECTKEY 01] to [EFFECTKEY 06] to play required play function (see section 2.3.3 for further information on how to patch [EFFECTKEY])
- Select [SPEED (+)] or [SPEED (-)] to adjust speed play function.
- It is not possible to adjust the light level of the EFFECT programs using the [DIMMER] keys.

### 5.4 COLOR CONTROLS

- Select from [COLORKEY 01] to [COLORKEY 06] to play required pre-set color (see section 2.3.3 for further information on how to create/edit [COLORKEY])
- Adjust light level using the [DIMMER] keys.
- Edit colors by press & holding a [COLORKEY] until lighting fixtures flash, then adjust using [RED], [GREEN], [BLUE], [STROBE] and [DIMMER] keys. (exit by selecting any other key)

## AR2.S

CHANNEL	VALUE	FUNCTION
1	0 ↔ 255	DIMMER
2	0 ↔ 255	RED
3	0 ↔ 255	GREEN
4	0 ↔ 255	BLUE
5	0 ↔ 255	WHITE
6	0 ↔ 255	STROBE

## HSV

CHANNEL	VALUE	FUNCTION
1	0 ↔ 255	HUE
2	0 ↔ 255	SATURATION
3	0 ↔ 255	VALUE

## 5 OPERATION WITH WIRELESS DMX

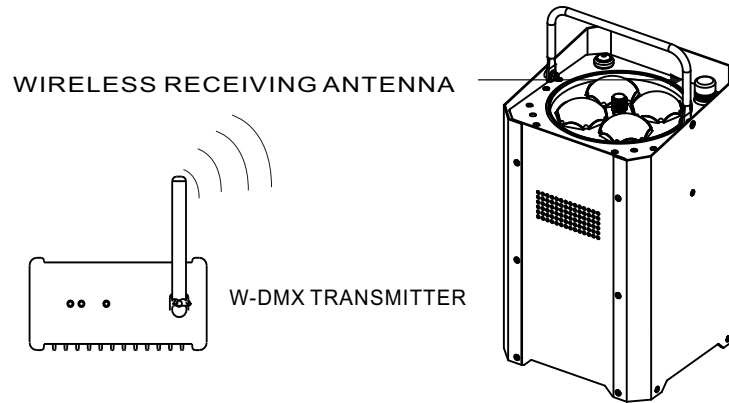

- 5.1 When using this lighting fixture with W-DMX receiver installed inside, the fixture may be placed at a range of 300m from W-DMX transmitter
- 5.2 Select DMX from the <RUN> menu.
- 5.3 Select ACTI from the <WDMX> menu and proceed to turn ON the WDMX. If the WDMX receiver card is already paired with a WDMX transmitter then the fixture is ready for receiving DMX signal. If the WDMX receiver card needs to be paired with a new WDMX transmitter, select YES from the <WDMX >/<REST> menu. The green signal indicator LED will not show which confirms that WDMX receiver card is unpaired and ready for new pairing.

## ZOOM RANGE (7~60°)

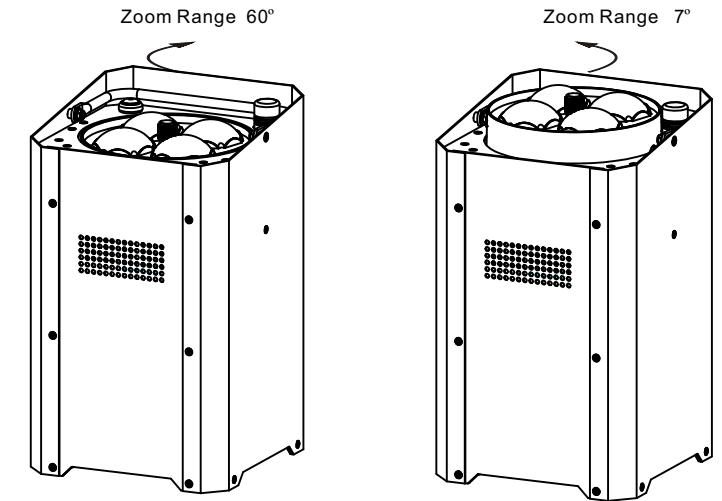

## 2.2 BATTERY CHARGING INPUT

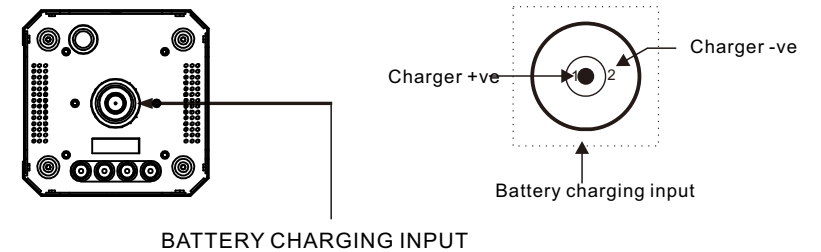

- Do not connect DMX
- Only for specified charger(in flight case or single charger)
- Do not connect any other data cables

## 2.3 GENERAL OPERATION

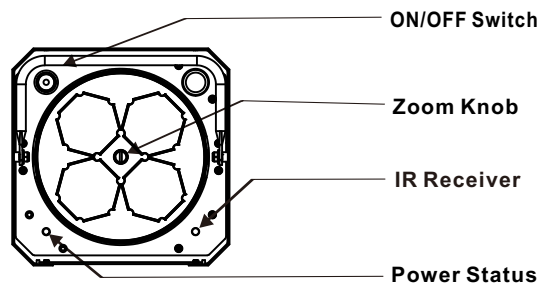

GREEN: >70%  
YELLOW: >20%  
RED: EMPTY

### 2.3.1 POWER STATUS

- During operation, the **Power Status** indicator will indicate the amount of battery power that is remaining. The battery should be recharged when RED is shown.
- During charging, the **Power Status** indicator will indicate the amount of battery power that has been charged to the battery. When the battery is fully charged the GREEN LED will immediately switch off.
- In the event that the battery storage switch is OFF, it is not possible to charge the battery. In this case, when the mains power is connected to the fixture, the **Power Status** indicator will show GREEN for 30 seconds and then fade out. This shows that electrical contact has been made between the lighting fixture and the battery charging system. The **Battery Storage Switch** must be ON in order to charge the battery.
- In order to check the current status of the battery, the battery charging system should be turned OFF. The fixture can then be turned ON using the EVENT ON/OFF button and the **Power Status** can be checked.

### 2.3.2 ON/OFF SWITCH

- Press the SWITCH ON/OFF button for 3 seconds to turn on/off lighting fixture (when BATTERY SWITCH is ON)
- SWITCH ON/OFF button indicator LED when showing constant RED indicates lighting fixture is power ON (when slowly flashing indicates that DMX data is successfully received)

## 2.4 OTHER OPERATIONS

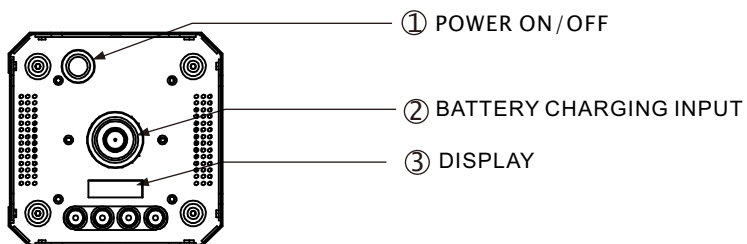

### 2.4.1 ANTENNA RELEASE

- When releasing support antenna with hand

### 2.4.2 BATTERY SWITCH

- ON for operation/charging
- OFF for storage (>7 days)
- OFF for maintenance
- Always use the **Battery Switch** when storing for more than 7 days
- **Battery Switch** must be ON for operation and charging

### ARC.1

CHANNEL	VALUE	FUNCTION
1	0 ↔ 255	RED
2	0 ↔ 255	GREEN
3	0 ↔ 255	BLUE

### ARR.D

CHANNEL	VALUE	FUNCTION
1	0 ↔ 255	MASTER DIMMER
2	0 ↔ 255	RED
3	0 ↔ 255	GREEN
4	0 ↔ 255	BLUE

### ARC2

CHANNEL	VALUE	FUNCTION
1	0 ↔ 255	RED
2	0 ↔ 255	GREEN
3	0 ↔ 255	BLUE
4	0 ↔ 255	WHITE

### AR2.D

CHANNEL	VALUE	FUNCTION
1	0 ↔ 255	DIMMER
2	0 ↔ 255	RED
3	0 ↔ 255	GREEN
4	0 ↔ 255	BLUE
5	0 ↔ 255	WHITE