

25x15W RGBW Quad LED Moving head

Zoom + Pixel control

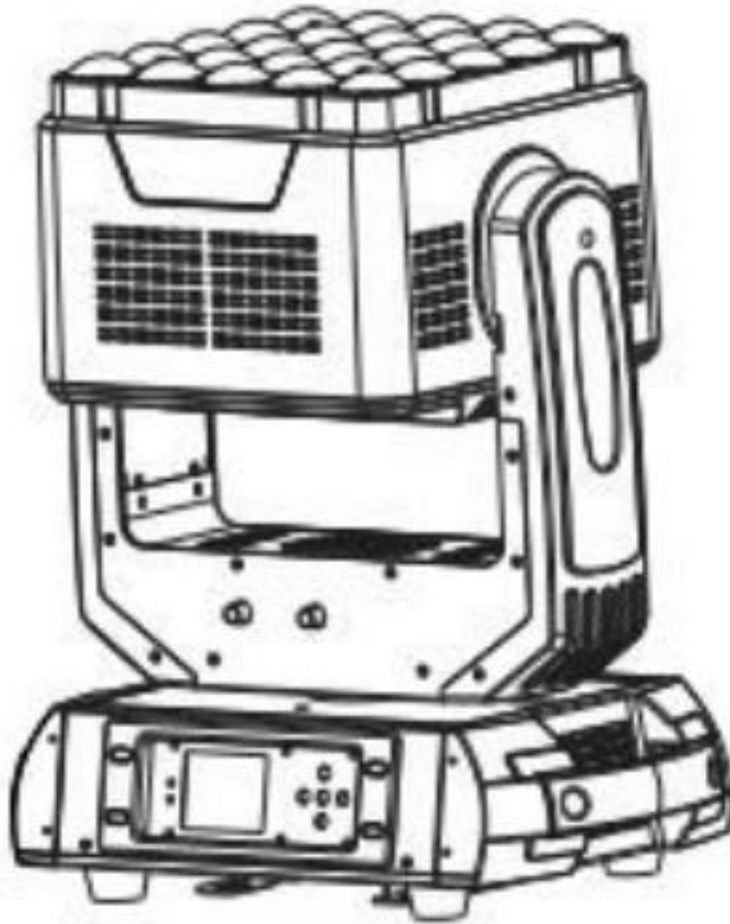

User Manual



PLEASE KEEP THE MANUAL FOR FUTURE NEEDS

Content

1. Introduction.....	3
2. Technical Parameter.....	4
3. Installation.....	5
4. Dimmer Modes & DMX512 Connect.....	6
5. LCD Display.....	7-8
6. Address Setting.....	9
7. Channels & Value& Function.....	9-11
8. Troubleshooting.....	12
9. Fixture Cleaning.....	12

Thank you for your patronage. We are confident that our excellent products and service can satisfy you. For your own safety, please read this user manual carefully before installing the device.

In order to install, operate, and maintain the lighting safety correctly. We suggest that the installation and operation should be done by the verified technician and follow the instruction strictly.



CAUTION!

Keep this device away from rain and moisture!



CAUTION!

Unplug mains lead before opening the housing.

Any person involved with the installation, operation and maintenance of this device has to:

- be qualified
- follow carefully the instructions of this manual

1. Introduction

Thank you for having chosen this professional moving head.

You will see you have acquired a powerful and versatile device.

Unpack the device. Inside the carton box you should find:

- a. Moving Head 1 unit
- b. Signal Cable 1 pc
- c. Power Cable 1 pc
- d. User Manual 1 unit
- e. Fasten Lock/Quick Couplers 1 pair

(Flight case, Safety cable and Clamps are optional, please contact your dealer)

Please check carefully that there is no damage caused by transportation. Should there be any problem, please consult your dealer and don't install this device.

2. Technical Parameter

- ◆ fast and powerful LED moving beam and wash.
- ◆ DMX Channels: 19/24/124 channels mode
- ◆ Operation modes: DMX 512, Master/Slave,Auto,Built-in program
- ◆ Great built-in lighting shows under Master/Slave mode
- ◆ Touch screen for easy navigation,PowerCon connection,3PIN and 5PIN DMX port
- ◆ Perfect for stage, theatre, TV studio, rental and discotheques
- ◆ If using a 230V 50Hz power supply, DO NOT connect in series more than 10 units; use another main supply for the next 10 fixtures.
- ◆ If using a 120V 60Hz power supply, DO NOT connect in series more than 5 units; use another main supply for the next 5 fixtures.
- ◆ Input Voltage:AC 100V~240V, 50/60Hz
- ◆ Power consumption: 400W
- ◆ Drive current: 830mA
- ◆ LED Lighting source: 25 X 15W RGBW LEDs
- ◆ Dimension: 412 X 280 X 524 mm
- ◆ Net Weight: 16.5kg
- ◆ Beam Angel: 8°-58°

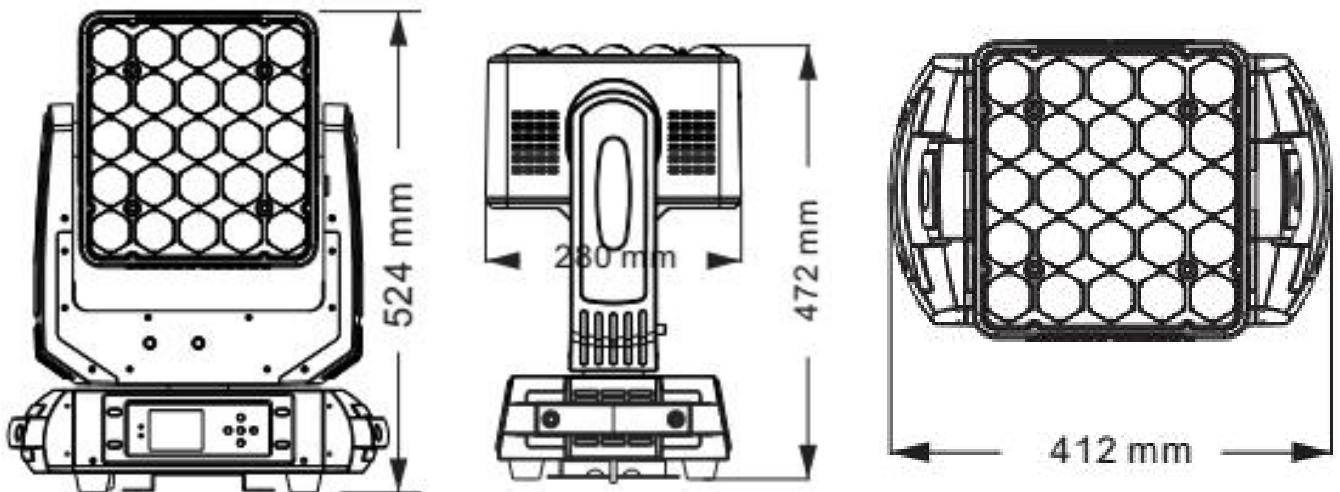

Testing report (Distance: 4 and 5 Meters, zoom Minimum)

Color	Wave Length	Driver Current	4Meters Lux	5Meters Lux
Red	635nm	830mA	3120 lux	2410 lux
Green	516nm	830mA	8226 lux	5528 lux
Blue	448nm	830mA	1540 lux	1118 lux
White	7387K	830mA	8883 lux	6236 lux
LED Full On		830mA	21206 lux	15600 lux

◆ **Housing Material:** The fixture adopts anti-heat plastic and die-cast aluminum according to ISO international standards, and embody the feeling of technical.

◆ **Control Mode**

Four control modes for your option: master-slave, auto-run, Built-in program and international standard protocol DMX512.

Application Area

Any professional performance places. eg: Large-scale lives, theater, studio, nightclubs and discos.

Packing:

Carton packing:

LxWxH(CM): 580 x 360 x 500mm

Gross weight: 19.5kg

3. Installation

Before installation, please read the user manual carefully, then prepare Fasten Lock(2 pcs), Clamps (2 pcs), and Safety Rope (1 pc).

- a. Upward the moving beam bottom, use 2 pcs Fasten Lock tighten at bottom of moving beam. Check it again.
- b. Hang up the fixture on the truss by clamps, tighten according to the truss diameter.
- c. Use the safety Rope tighten for safety issue.

4. Dimmer Modes & DMX512 Connection

Dimmer Modes

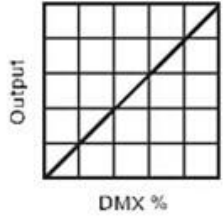

Optically Linear

.....DMX CONNECT

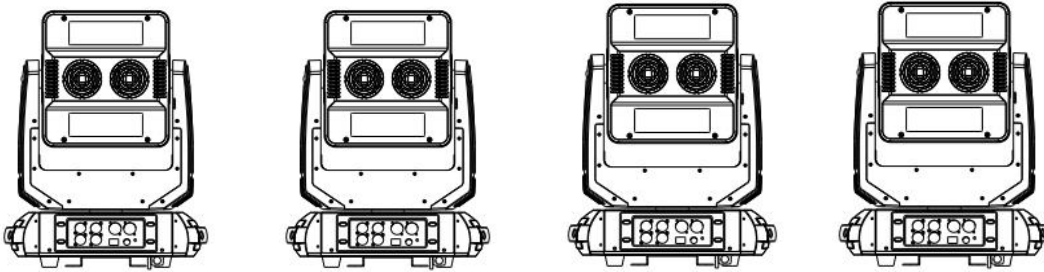

DMX IN

DMX OUT



DMX CONTROLLER

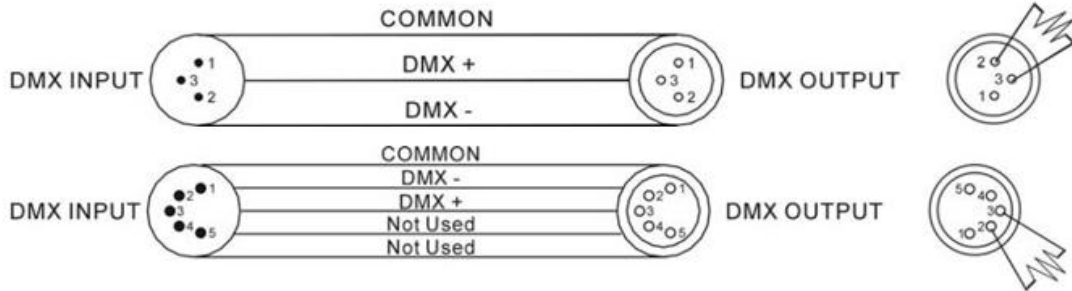

5. LCD Display

Main Menu	Sub-Menu	Description
SET	Run Mode	DMX / Auto/ Master/Slave
	DMX Address	Press up and down key to choose the address value(001~512)
	Channel Mode	19CH Mode1/24CH Mode2/124CH Mode3
	X Invert	OFF / ON
	Y Invert	OFF / ON
	LCD Backlight	OFF / ON
	Color Dimmer	Linear/Square
	Graphic Display	OFF / ON
	Color Mixing	RGBW / CMY
	PAN/Tilt Mode	Speed / Time
	Blackout Moving	OFF / ON
	FAN Mode	Auto / High
	System Reset	All Reset / PAN / Tilt Reset / zoom Reset
	Restore Setting	
MANL	Pan	Press up and down buttons to adjust the fixture pan degree
	Pan Fine	Pan degree Fine
	Tilt	Press up and down buttons to adjust the fixture tilt degree
	Tilt Fine	Tilt degree Fine
	Pan Control	Pan polar rotation
	Tilt Control	Tilt polar rotation
	Speed	Press up and down buttons to change the speed of pan/tilt
	P/S function	LED DMX setting
	Color wheel	Press up and down buttons to choose the mixing color and Color Jump
	Red/Cyan	Press up and down buttons to add/reduce the lux of color red/cyan
	Red/Cyan Fine	Press up and down buttons to add/reduce the lux of color red/cyan fine
	Green/Magenta	Press up and down buttons to add/reduce the lux of color green/magenta
	Green/Magenta Fine	Press up and down buttons to add/reduce the lux of color green/magenta fine
	Blue/Yellow	Press up and down buttons to add/reduce the lux of color blue/yellow

	Blue/Yellow Fine	Press up and down buttons to add/reduct the lux of color blue/yellow fine
	White	Press up and down buttons to add/reduct the lux of color white
	White Fine	Press up and down buttons to add/reduct the lux of color white fine
	CTC	Press up and down buttons to choose the different white light
	Pixel effects	Function for the back light LED board
	Pixel effects Speed	Function speed
	Zoom	Press up and down buttons to adjust the optical lens angle
	Strobe	Press up and down buttons to change the speed of Strobe with dimming Channel switch
	Dimmer	Press up and down buttons to adjust the fixture brightness from dark to full bright(0~100%)
	Dimmer Fine	Adjust the fixture brightness from dark to full bright fine
	Red1	Press up and down buttons to add/reduce the lux of color red 1
	Green1	Press up and down buttons to add/reduce the lux of color green 1
	Blue1	Press up and down buttons to add/reduce the lux of color blue 1
	White1	Press up and down buttons to add/reduce the lux of color white 1
	Red2	Press up and down buttons to add/reduce the lux of color red 2
	Green2	Press up and down buttons to add/reduce the lux of color green 2
	Blue2	Press up and down buttons to add/reduce the lux of color blue 2
	White2	Press up and down buttons to add/reduce the lux of color white 2

	Red25	Press up and down buttons to add/reduce the lux of color red 25
	Green25	Press up and down buttons to add/reduce the lux of color green 25
	Blue25	Press up and down buttons to add/reduce the lux of color blue 25
	White25	Press up and down buttons to add/reduce the lux of color white 25
INFOR	Display Version	Software version
	Display Infor	This is date we manufactured the LCD board
	Master Infor	This is date we manufactured the main board
	Total use time	This is the time we have used for the light from the production so far.
	The Use Of Time	This is the time when we use the light on the electricity
	LED Temperature	This is LED temperature display
EXPE	Password	Adjust the calibration data
↓		↓↑ LCD Reverse

6. Address Setting

If you use a universal DMX controller to control the units, you have to set DMX address from 1 to 512 so that the units can receive DMX signal. Rotate MENU knob to enter menu mode, select DMX Functions, press knob to confirm, press knob to select DMX Address, press knob to confirm, the present address will blink on the display, rotate the knob to adjust the address from 0 to 512, press the knob to store.

Please refer to the following diagram to address your DMX512 channel for the first 4 units

Channel mode	Unit 1 Address	Unit 2 Address	Unit 3 Address	Unit 4 Address
19 channels	1	20	39	58
24 channels	1	25	49	73
124 channels	1	125	249	373

7.Channels chart

Channel modes			Function	Value	Detail information
1	1	1	Pan	0~255	Pan (8bit)
2	2	2	Pan Fine	0~255	Pan Fine (16bit)
3	3	3	Tilt	0~255	Tilt (8bit)
4	4	4	Tilt Fine	0~255	Tilt Fine (16bit)
5	5	5	Pan control	0~55 56~155 156~255	No function Continuous rotation from fast to slow, forwards Continuous rotation from slow to fast, Backwards
6	6	6	Tilt control	0~55 56~155 156~255	No function Continuous rotation from fast to slow, forwards Continuous rotation from slow to fast, Backwards
7	7	7	Pan/Tilt Speed	0~255	From fast to slow
8	8	8	DMX setting	0~50 51~65 66~80 81~110 111~125 126~140 141~170 171~185 186~200 201~205	Reserved RGBW color mixing mode CMY color mixing mode Reserved Blackout while pan/tilt moving Disabled blackout while pan/tilt moving Reserved Fans mode:Auto (if temp>40°C fans high) Fans mode: high Reserved

				206~220 221~235 236~250 251~255	Pan/Tilt reset Zoom reset All reset Reserved
9	9	9	Virtual color wheel	0 1~2 3 4~5 6 7~9 10~12 13~15 16 17~55 56 57~95 96 97~134 135 136~174 1756 176~214 215 216~246 247 248~255	No function White 2700K White 2700K (Halogen lamp mode) White 3200K White 3200K (Halogen lamp mode) White 4200K White 5600K White 8000K Blue Red=0,Green=up,Blue=full,White=0 Red=0,Green=full,Blue=full,White=0 Red=0,Green=full,Blue=down,White=0 Red=0,Green=full,Blue=0,White=0 Red=up,,Green=full,Blue=0,White=0 Red=full,Green=full,Blue=0,White=0 Red=full,Green=down,Blue=0,White=0 Red=full,Green=0,Blue=0,White=0 Red=full,Green=0,Blue=up,White=0 Red=full,Green=0,Blue=full,White=0 Red=down,Green=0,Blue=full,White=0 Red=0,Green=0,Blue=full,White=0 Rainbow effect
10	10	10	Red/Cyan	0~255	Red/Cyan (8bit)
*	11	11	Red/Cyan Fine	0~255	Red/Cyan (16bit)
11	12	12	Green/Magenta	0~255	Green/Magenta (8bit)
*	13	13	Green/Magenta Fine	0~255	Green/Magenta (16bit)
12	14	14	Blue/Yellow	0~255	Blue/Yellow (8bit)
*	15	15	Blue/Yellow Fine	0~255	Blue/Yellow (16bit)
13	16	16	White	0~255	White(8bit) if CMY mode selected no function
*	17	17	White Fine	0~255	White(16bit) if CMY mode selected no function
14	18	18	CTC	0~255	CTC
15	19	19	RGBW function	0~2 3~206	No function Effect 1 to 41

				207~254 255	Effect run RGBW 100%
16	20	20	RGBW function speed	0~255	From slow to fast
17	21	21	zoom	0~255	zoom
18	22	22	Shutter/Strobe	0~31 32~63 64~95 96~127 128~143 144~159 160~191 192~223 224~255	Shutter close Shutter Open Strobe effect from slow to fast Shutter Open Opening pulse in sequences from slow to fast Closing pulse in sequences from slow to fast Shutter Open Random strobe-effect from slow to fast Shutter Open
19	23	23	Dimmer	0~255	Dimmer (8bit)
*	24	24	Dimmer Fine	0~255	Dimmer Fine (16bit)
*	*	25	Red Pixel 1	0~255	Red Pixel 1
*	*	26	Green Pixel 1	0~255	Green Pixel 1
*	*	27	Blue Pixel 1	0~255	Blue Pixel 1
*	*	28	White Pixel 1	0~255	White Pixel 1
*	*
*	*	121	Red Pixel 25	0~255	Red Pixel 25
*	*	122	Green Pixel 25	0~255	Green Pixel 25
*	*	123	Blue Pixel 25	0~255	Blue Pixel 25
*	*	124	White Pixel 25	0~255	White Pixel 25

8. Troubleshooting

Following are a few common problems that may occur during operation. Here are some suggestions for easy troubleshooting:

A. The unit does not work, no light and the fan does not work

1. Check the connection of power and main fuse.
2. Measure the mains voltage on the main connector.
3. Check the power on LED.

B. Not responding to DMX controller

1. DMX LED should be on. If not, check DMX connectors, cables to see if link properly.
2. If the DMX LED is on and no response to the channel, check the address settings and DMX polarity.
3. If you have intermittent DMX signal problems, check the pins on connectors or on PCB of the unit or the previous one.
4. Try to use another DMX controller.
5. Check if the DMX cables run near or run alongside to high voltage cables that may cause damage or interference to DMX interface circuit.

C. One of the channels is not working well

1. The stepper motor might be damaged or the cable connected to the PCB is broken.
2. The motor's drive IC on the PCB might be out of condition.

9. Fixture Cleaning

The cleaning of internal and external optical lenses and/or mirrors must be carried out periodically to optimize light output. Cleaning frequency depends on the environment in which the fixture operates: damp, smoky or particularly dirty surrounding can cause greater accumulation of dirt on the unit's optics.

- ◆ Clean with soft cloth using normal glass cleaning fluid.
- ◆ Always dry the parts carefully.
- ◆ Clean the external optics at least every 20 days. Clean the internal optics at least every 30/60 days.